

正方形リンク形単相駆動超音波モータ

田村 英樹 (東北工大)・高野 剛浩 (東北工大)

Hideki Tamura (Tohoku Inst. of Tech), Takehiro Takano (Tohoku Inst. of Tech)

構造と動作原理

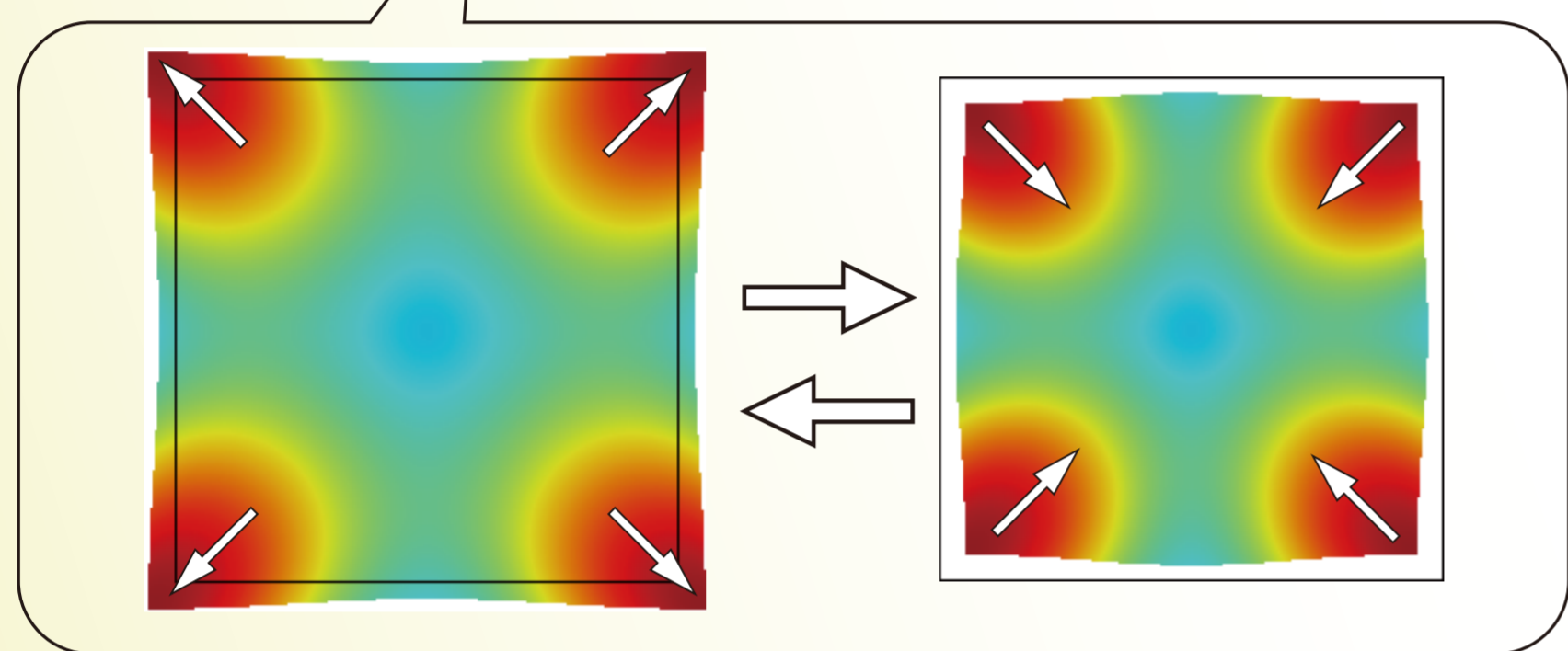
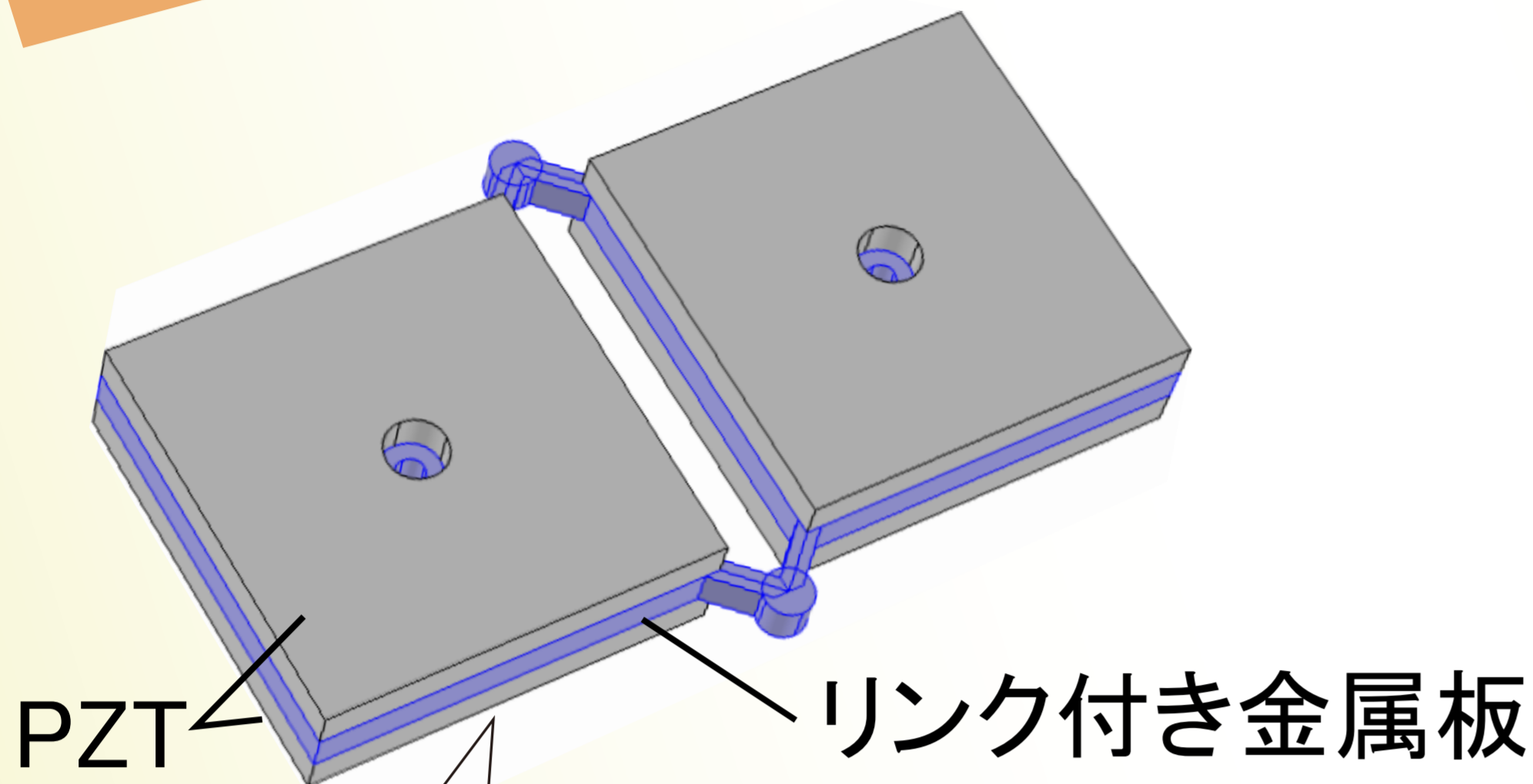

正方形の面内呼吸モード

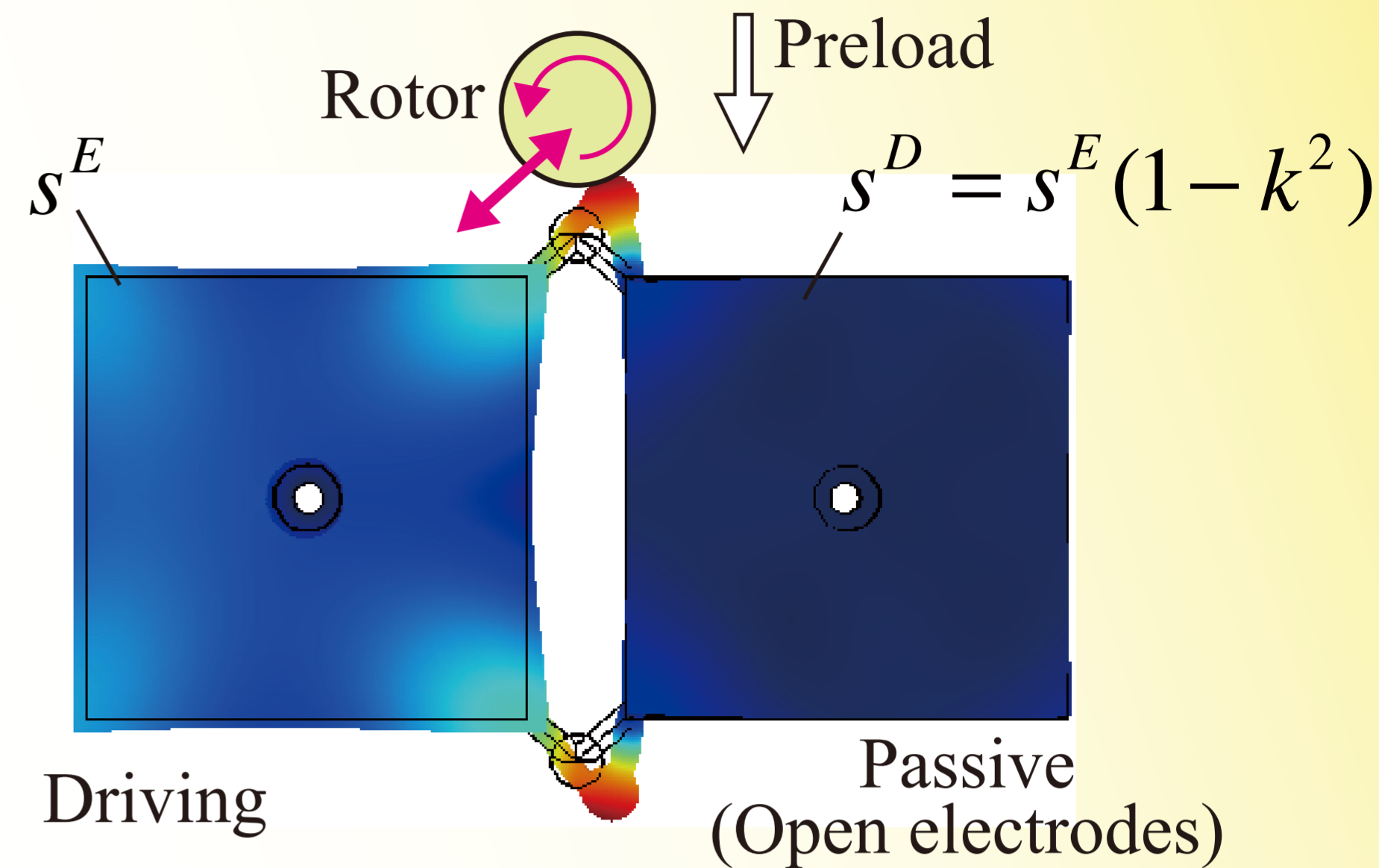
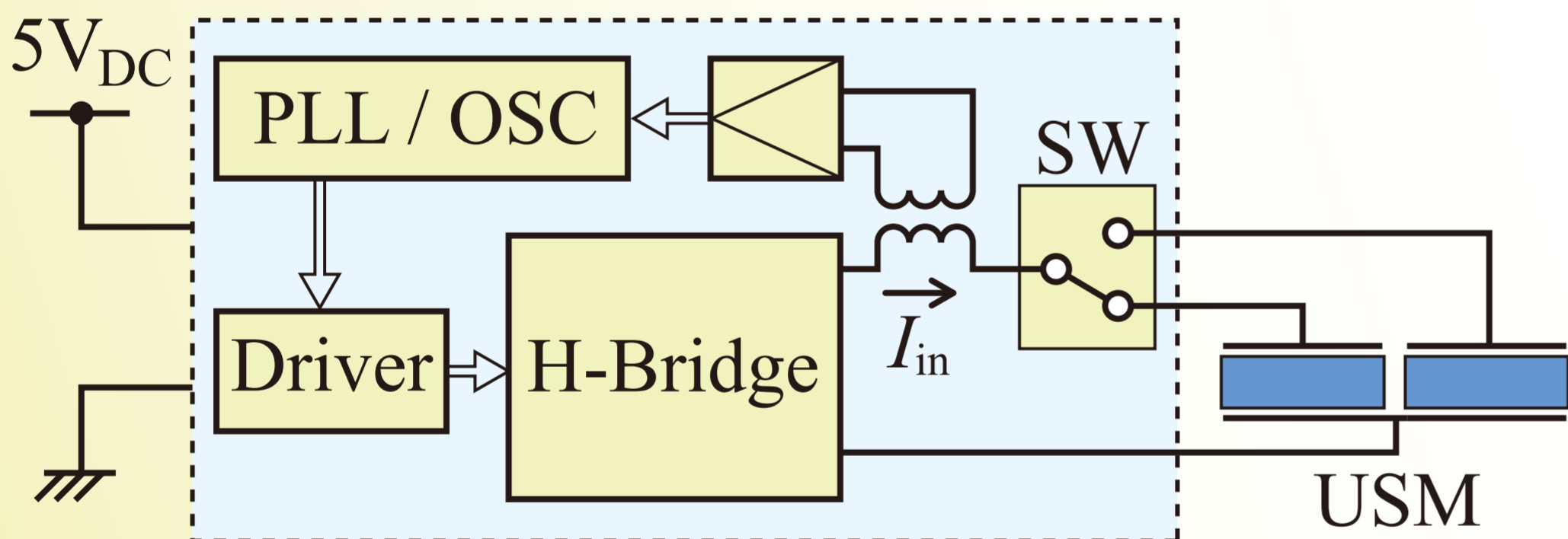

左側正方形のみ駆動→左回転

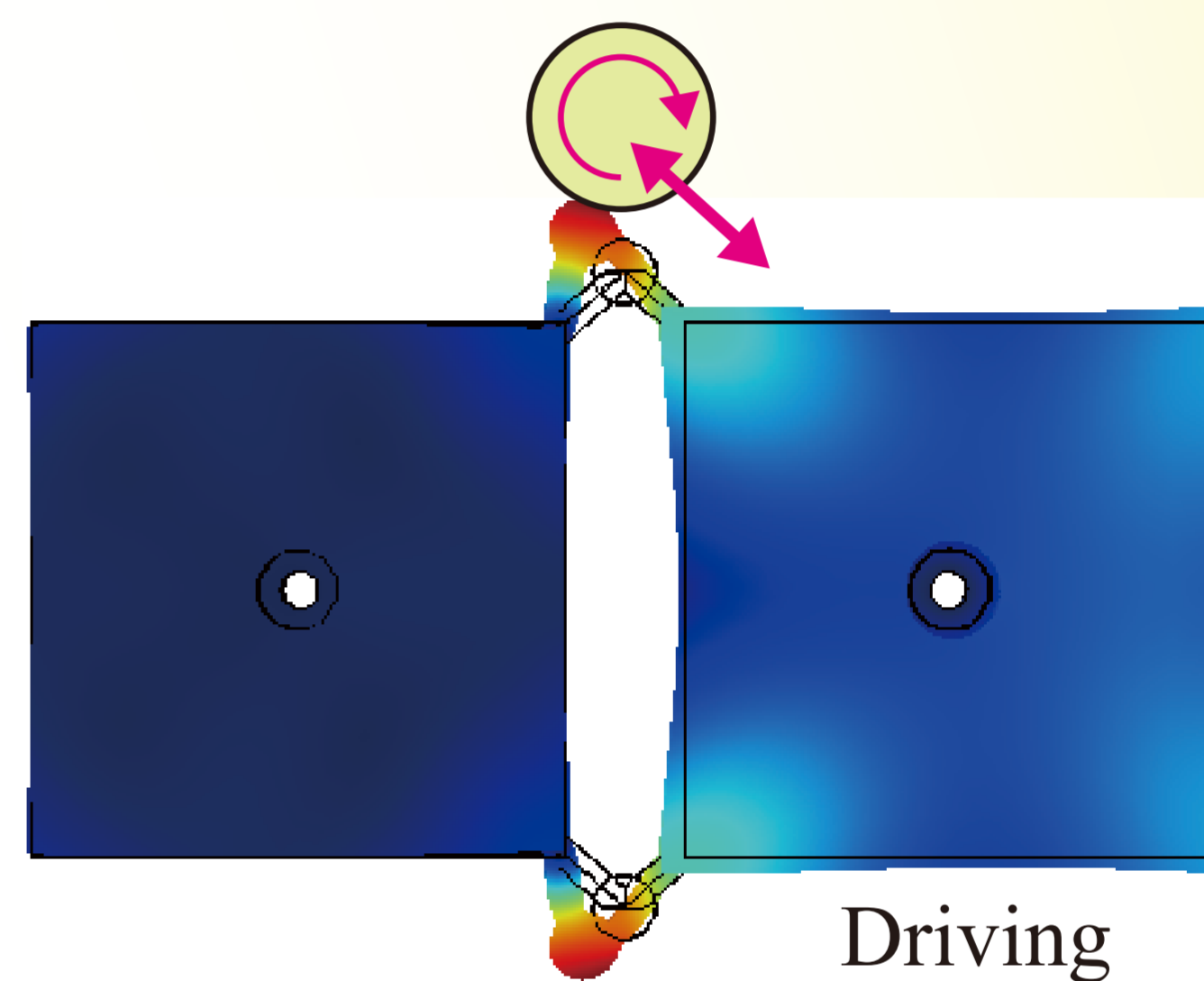

右側正方形のみ駆動→右回転

駆動端子切換のみで逆転可能

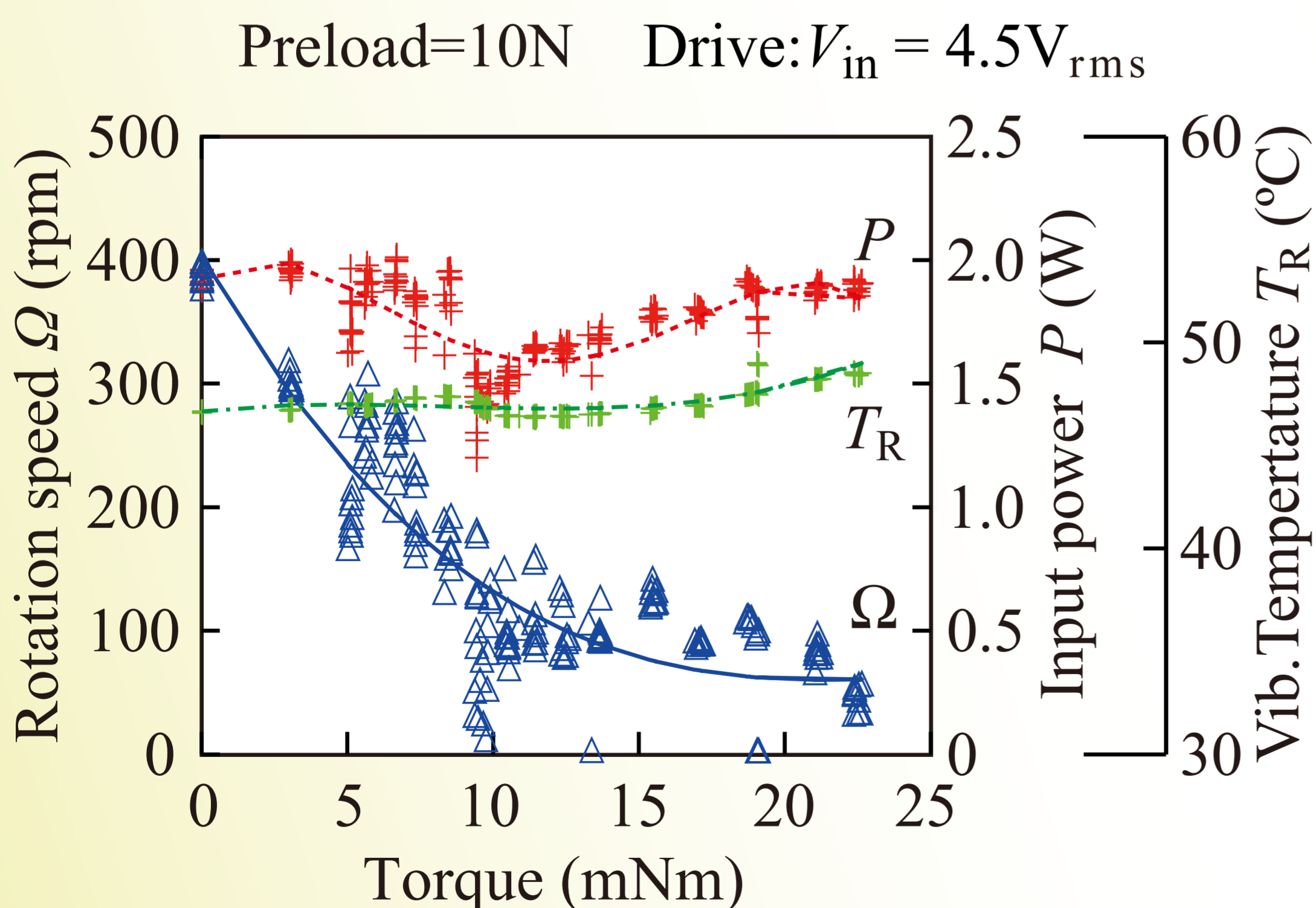

回転型モータの特性例(連続回転)

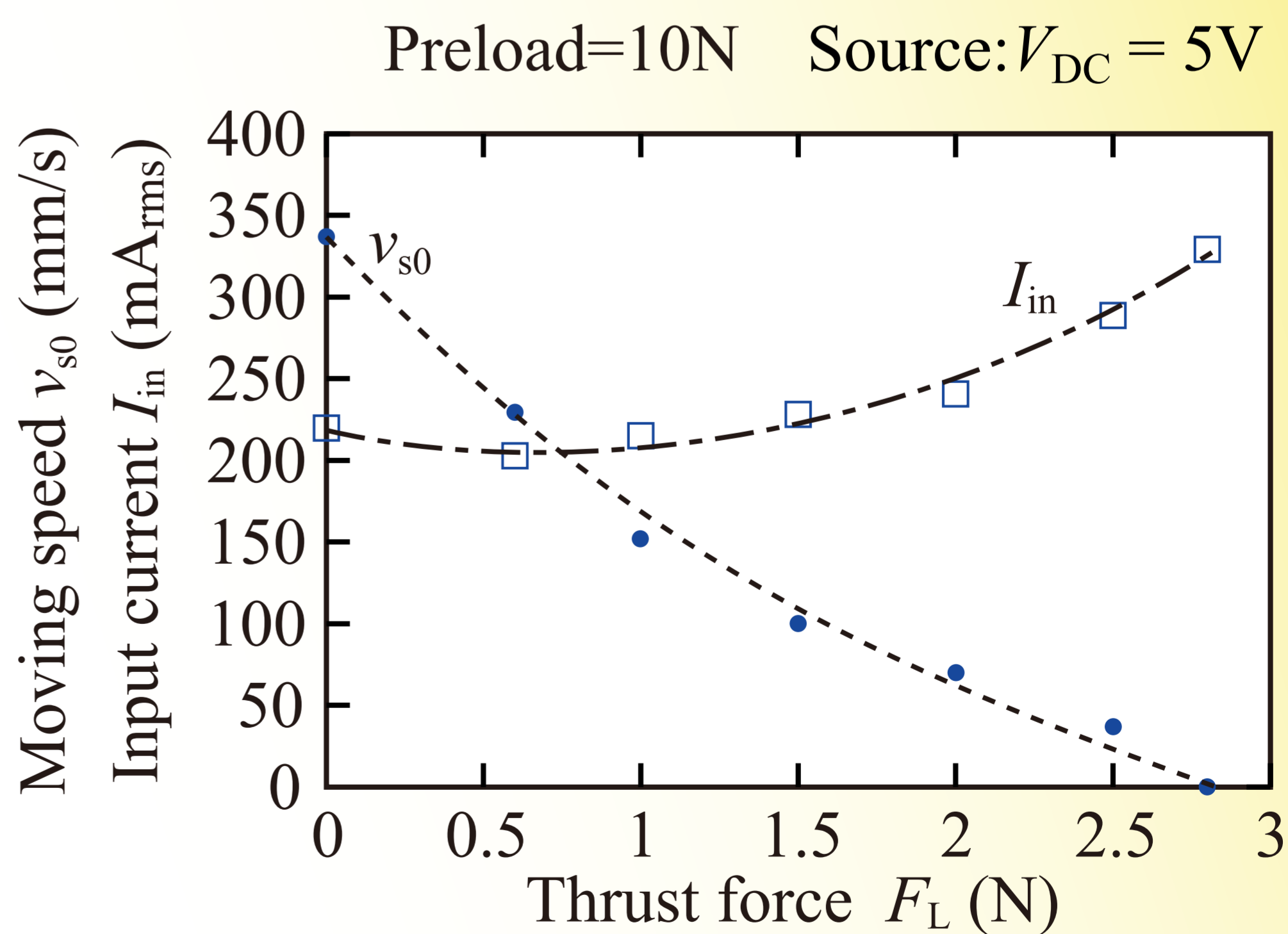

リニア型モータの特性例